

Type CLG-1-S1 - ** - ** - ** C

Common type Switch The space between H and L Size from under flange to center of float

1 2 3

1

CODE	Switch
00	None
0C	One for lower limit
C0	One for upper limit
CC	One each for upper and lower limits space between H and L
3C	Three
4C	Four

2

The space between H and L	"A" Size
~ 50 mm	132 mm
55 ~ 100 mm	182 mm
105 ~ 150 mm	232 mm
155 ~ 200 mm	282 mm
205 ~ 250 mm	332 mm
255 ~ 300 mm	382 mm
305 ~ 350 mm	432 mm
355 ~ 400 mm	482 mm
405 ~ 450 mm	532 mm
455 ~ 500 mm	582 mm

3

SIZE	Size from under flange to center of float
50	The custom-designed size of 50mm or more can be produced.

Specification of Auto-switch

Load voltage	AC/DC 10~100V
Load current	3 - 20 mA
Response time	1 ms
Impact resistance	30 G
Ambient temperature	-10 ~ 60 °C
Internal voltage drop	MAX 4V

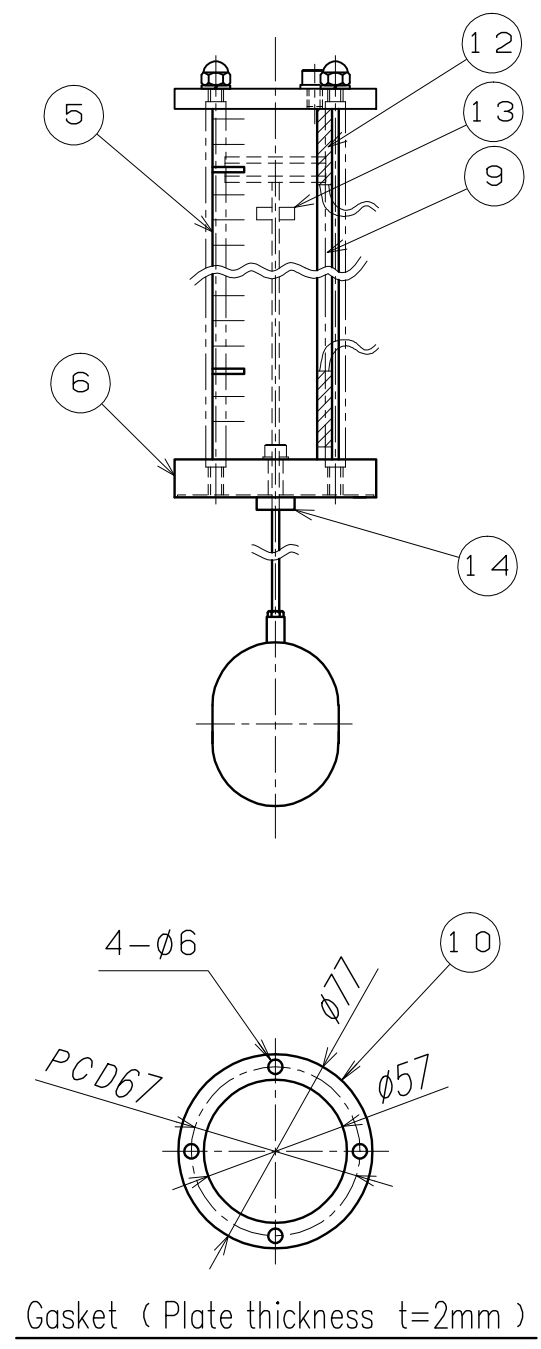

14	Stopper	1	Aluminum	AL12-001	
13	Stopper	1	Aluminum	AL12-001	
12	Auto switch	**		S·SWC-1-G-K	
11	Hexagon socket bolt	4		M5	
10	Gasket	1	Silicone rubber	G67-001	
9	Switch rail	1	Acrylic	L150-001	
8	Float	1	Polypropylene	W50-001	
7	Shaft	1	SUS304	P3-002	
6	Flange	1	Aluminum	F80A-020	
5	Pipe	1	Polyarylate	S50-002	
4	Magnet	1		CM40-001	
3	Spacer	2	Acrylic	MS40-001	
2	Pipe & Free-size Bolt or Tie rod	4	SUS304 & SS400	Pipe (SUS304) & FREE-SIZE BOLT (SS400) or Ø8 Tie rod (SUS304)	
1	Flange	1	Aluminum	F80A-010	
No.	PART NAME	Q'TY	MATERIAL	TYPE	REMARKS
APPROVED	CHECKED	DESIGNED	SCALE	NAME	
			1/3		

Address 1519, Wakabadai
Meito-ku, Nagoya-shi, Aichi 465-0015,
Japan
Tel: 052-760-3365 Fax: 052-760-3375

Note
2015.04.01

APPROVED CHECKED DESIGNED SCALE NAME
1/3
CLEAN LEVEL TOWER (Type: Machining Oil)
CLG-1-S1-**-**-**C
KOIKE E&S CO., LTD.